

Übersetzung von nach R 36911

Zusammengestellt nach R 36912

Printed in West Germany



ROHDE & SCHWARZ
MÜNCHEN

Manual

MULTI-COUPLER
TYPE NV14T

Table of Contents

<u>1.</u>	<u>Characteristics</u>	4
1.1	Uses	4
1.2	General Description	4
1.3	Specifications	6
1.4	Recommended Accessories	7
<u>2.</u>	<u>Preparation for Use and</u> <u>Operating Instructions</u>	8
2.1	Key to Numbers on Fig. 1	8
2.1.1	Connection to Power-supply Section	8
2.1.2	Connection of RF Cables	8
2.2	Operating Instructions	8
<u>3.</u>	<u>Maintenance and Repair</u>	9
3.1	Required Measuring Instruments and Accessories	9
3.2	Maintenance Instructions	11
3.2.1	Electrical Maintenance	11
3.2.2	Checking the Nominal Characteristics	11
3.2.2.1	Frequency Response and Input Impedance	11
3.2.2.2	Isolation Between Outputs	14
3.2.2.3	Noise Figure	15
3.2.2.4	Gain	18
3.2.2.5	Suppression of Intermodulation Distortion ($d_2 + d_3$)	19
3.2.2.6	Cross Modulation	22
3.2.3	Recalibration	24
3.2.4	Mechanical Maintenance	24
3.3	Repair Instructions	25
3.3.1	Circuit Description	25
3.3.1.1	Overvoltage Protection and Filter	25

3.3.1.2	Amplifier Section	25
3.3.1.3	Output Coupling Network	26
3.3.1.4	Negative Feedback	26
3.3.1.5	Current Regulator	26
3.3.1.6	Voltage Regulator	27
3.3.2	Mechanical Construction	28
3.3.3	Repair	28
3.3.3.1	Input Impedance	28
3.3.3.2	Gain	29
3.3.3.3	Noise Figure	29
3.3.3.4	Unwanted Mixture Products d_2 and d_3	29

Fig. 1	Rear view	31
Fig. 2	Component side	32
Fig. 3	Wiring side	33
Fig. 4	Block diagram	34

Translations for Drawings and Diagrams	35
--	----

Drawings and Diagrams

Standard Translations for Parts Lists

Supplement to Standard Translations for Parts Lists	36
---	----

Parts Lists

1. Characteristics

1.1 Uses

The Multicoupler Type NV 14 T is a wideband amplifier of low noise and distortion and operates in the shortwave range 1.6 to 30 MHz or 1.0 to 30 MHz, depending on the model. It permits the operation of as many as 10 receivers from a single antenna without loss of signal.

Together with the Power Supply Type NV 142 N, which is of the same size, the NV 14 T can be operated as a self-contained unit (in a small cabinet, dimensions: 185 x 150 x 122 mm) which can be mounted on the wall or used as a table model. The electrical and constructional design of the Multicoupler is such as to fulfil the requirements not only of small receiving stations with, say, 10 receivers, but also of large systems with more than 100 receivers. Since each Multicoupler has ten outputs, triple cascading permits the connection of as many as 1000 receivers to one antenna without noticeably affecting the reception characteristics of the system as compared with single operation. The Rack Adapter Type NV 142 E is used in such large systems for accommodating eight Multicouplers NV 14 T, which are fed from a common power supply incorporated in the Adapter. The Multicoupler can also be connected to an external power supply for 24 V \pm 0.5 V, 0.6 A.

1.2 General Description

Silicon transistors are used throughout. The input filter determines the frequency range. The operating range of the Multicoupler can be extended by changing the cutoff frequency of this filter, and due to its basic design can cover a much wider range without noticeable limitation of the characteristics. The input filter is followed by a common-base circuit and a two-stage emitter follower. Large negative feedback is common to all stages, npn-pnp transistor pairs being used in push-pull configuration to reduce 2nd and 3rd order distortions.

The Multicoupler is split into two functional units - an amplifier and a passive isolation network.

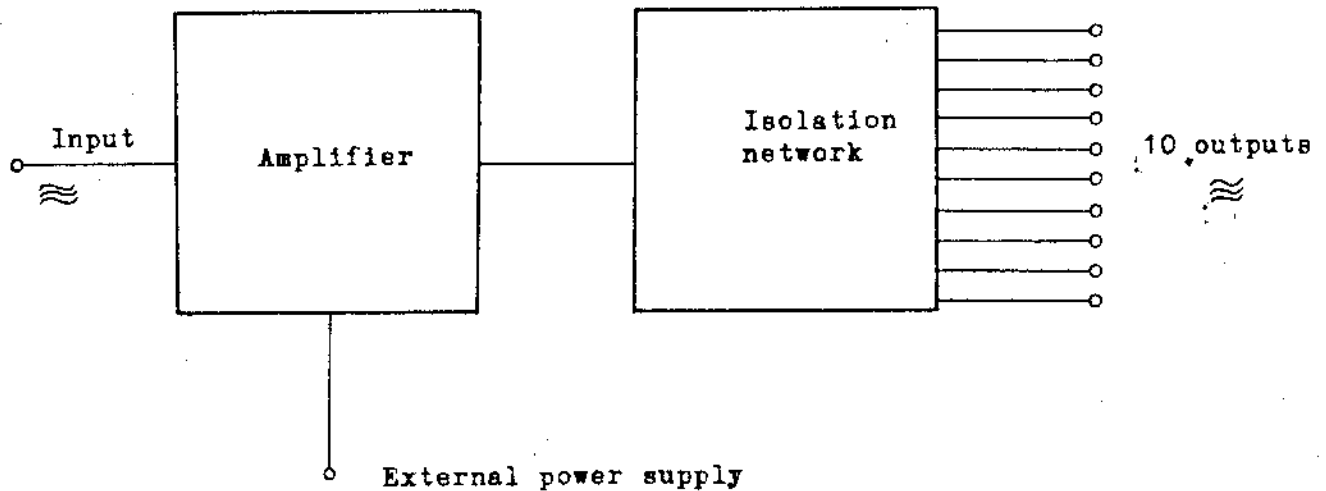

The antenna signal is amplified in the amplifier section, so that after distribution to the 10 outputs the full antenna signal is available.

The subsequent passive isolation network decouples the outputs of the Multicoupler. In this way mismatch of one output does not cause energy to be taken from the other outputs, nor can oscillator reradiation of one receiver be reflected back to the other receivers via the Multicoupler.

1.3 Specifications

Frequency range 1.6 to 30 MHz or
1.0 to 30 MHz

Input impedance 50 Ω , VSWR < 2

Output impedance 50 Ω , VSWR 1.1

Number of outputs 10

Phase difference between two
outputs $\pm 1^\circ$

Isolation between outputs > 40 dB

Input and output connections BNC sockets

Voltage gain 0 dB ± 0.5 dB

Noise figure see tolerance diagram
section 3.2.2.3

Mixture-product suppression for a
wanted transmitter EMF of 2 x 300 mV

for 2nd order mixture products
($f_1 \pm f_2$) 70 dB for all measured values
75 dB for more than 90% of all
measured values

for 3rd order mixture products
($2f_1 \pm f_2$) and ($f_1 \pm 2f_2$) 80 dB for all measured values
85 dB for more than 90% of all
measured values

Cross modulation: with interfering
transmitter modulated 30%, cross
modulation of 10% occurs

frequency of interfering
transmitter 1 to 10 MHz 10 to 20 MHz 20 to
30 MHz

EMF of interfering transmitter 4 V 3.4 V 2.6 V

General data

Power supply 24 ± 0.5 V

Current drain 500 mA max.

Permissible ambient
temperature -40°C to $+55^\circ\text{C}$

Dimensions (H x W x D) 132.5 x 52.6 x 175 mm

Weight 1.3 kg

1.4 Recommended Accessories

Power Supply Type NV 142 N

Cassette for Multicoupler

and Power Supply Type NV 142 K

Adapter for rack unit Type NV 142 E

(with power supply for
8 x NV 14 T)

Suitable patch cords, listed in the data sheet 902100 "Connectors".

Mating connectors for BNC input and output sockets: free plug
BNC FHM 10012/50.

Mating connector for DC Power Supply: free socket FO.063.7983

2. Preparation for Use and Operating Instructions

(see rear view, Fig. 1)

2.1 Key to Numbers on Fig. 1

1 to 10 outputs Bu1 to Bu10
11 AC-supply socket St12
12 input Bu11

2.1.1 Connection to Power-supply Section

Connect a power supply of 24 V \pm 0.5 V (0.6 A, max.) to 11 via a cable with the connector FO 063.7983.

2.1.2 Connection of RF Cables

The input and outputs are equipped with BNC sockets, $Z = 50 \Omega$. If all outputs are used, BNC connectors FHM 10012/50 (without compression nut) should be used.

2.2 Operating Instructions

The unit is ready for operation after switching on the operating voltage. No trimming or checks are required.

3. Maintenance and Repair

3.1 Required Measuring Instruments and Accessories

The following R&S equipment is required for checking and readjusting the Multicoupler.

Digital Multimeter UGWD, BN 1110

0.1 to 1000 V in 5 ranges

$Z_{in} > 10 \text{ M}\Omega$ (in the measuring range used)

for measurement of DC voltages

Power Supply NGR 50, BN 95145/50/2

0 to 50 V at 2 A

with adjustable current limiting, or Power Supply NV 142 N

Electronic Multimeter URI, BN 1050

0.1 μA to 1000 mA

for current measurements

Millivoltmeter UVN, BN 12003

0.1 mV_{rms} to 10 V_{rms} , $Z_{in} > 1 \text{ M}\Omega/30 \text{ pF}$

for measurement of voltages in the AF range

UHF Millivoltmeter URV, BN 10913 with Probe BN 10914/50

2 mV_{rms} to 10 V_{rms} , $Z = 50 \Omega$

for measurement of voltages in the RF range

T-Section, BN 42441/50, $Z = 50 \Omega$

Coaxial Changeover Switch SNB 4001/50, $Z = 50 \Omega$

SHF Termination RMC, BN 33527/50 Ω (2 required)

$Z = 50 \Omega$, Dezifix B (for BN 10914/50)

Polyskop SWOB, BN 4244/2

0.5 to 60 MHz, $Z = 50 \Omega$

for measurement of frequency response and input impedance

Coaxial Cable, BN 356815/50

Z = 50 Ω , length > 10 m

for measurement of input and output impedance

Power Signal Generator SMLR, BN 41001 (2 required)

0.1 to 30 MHz, 10 V max. into 60 Ω

for measurement of intermodulation distortion, cross modulation, gain and decoupling.

Matching Pad 60 Ω /50 Ω DAF, BN 18085 (2 required)

for matching of the Signal Generators

Noise Generator SKTU, BN 4151/2

Noise power 0 to 10 dB, Z = 50 Ω

for measurement of noise figure

Shortwave Receiver EK 07

0.5 to 30 MHz

used as a selective microvoltmeter for measurement of intermodulation distortion and noise figure

Cable, BN 9111105/50 (3 required)

Z = 50 Ω , length 0.3 to 0.5 m, Dezifix B or sockets which match the measuring instruments used

UHF Attenuator DPU, BN 18043/50

for measurement of noise figure and intermodulation distortion

3.2 Maintenance Instructions

3.2.1 Electrical Maintenance

Regular maintenance is not required

3.2.2 Checking the Nominal Characteristics

3.2.2.1 Frequency Response and Input Impedance

The frequency response and the input impedance are measured with the Polyskop Type SWOB.

Test setup for frequency-response measurement:

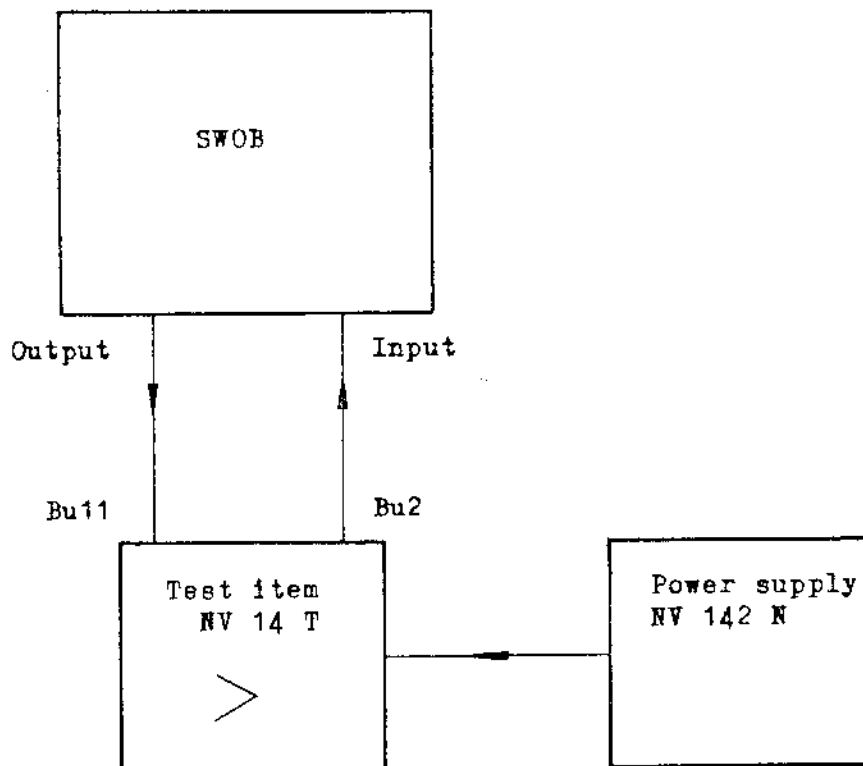

Measurement procedure:

Connect the Multicoupler between the input and output of the SWOB and switch on the power supply of 24 V \pm 0.5 V, 0.6 A (e.g. NV 142 N). The frequency response and gain should be within the following tolerance diagram:

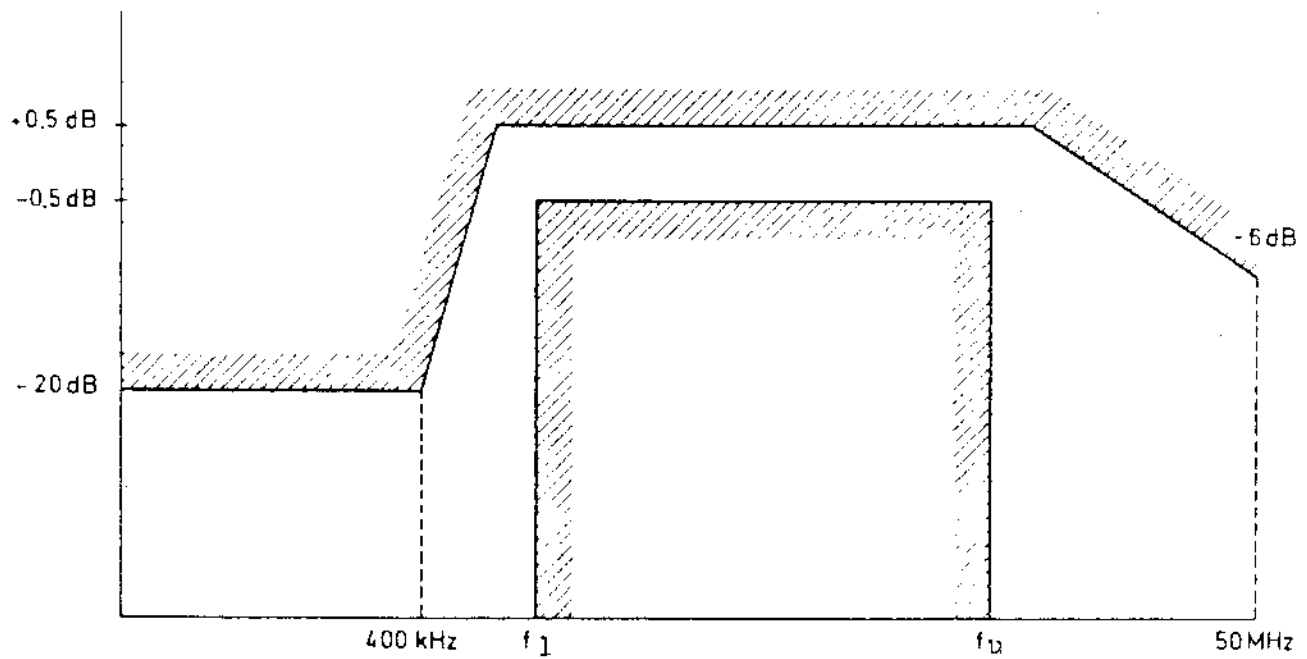

Test setup for input-impedance measurement (VSWR):

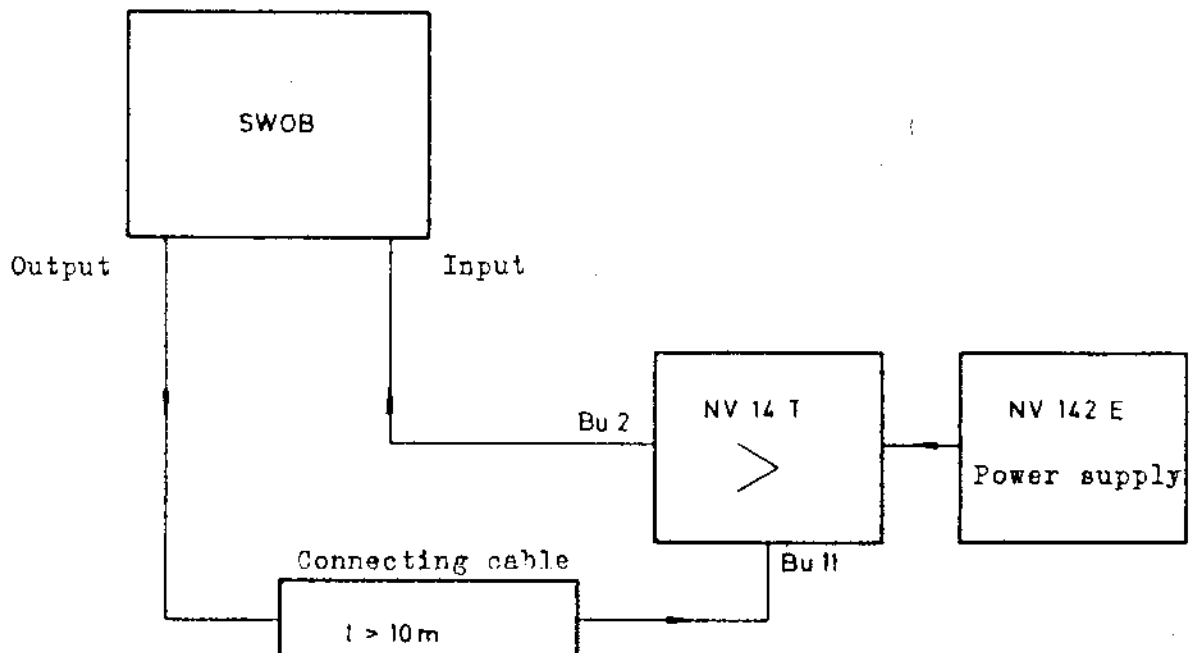

Measurement procedure:

Terminate the RF output of the SWOB with 50 Ω via the connecting cable and mark the position of the reference line.

Mark the lines corresponding to VSWR = 2 (terminate the cable with 25 Ω).

Connect the input of the Multicoupler (Bu11) to the RF output of the SWOB.

The indicated curve must lie within the tolerance limits over the total frequency range.

Tolerance limits:

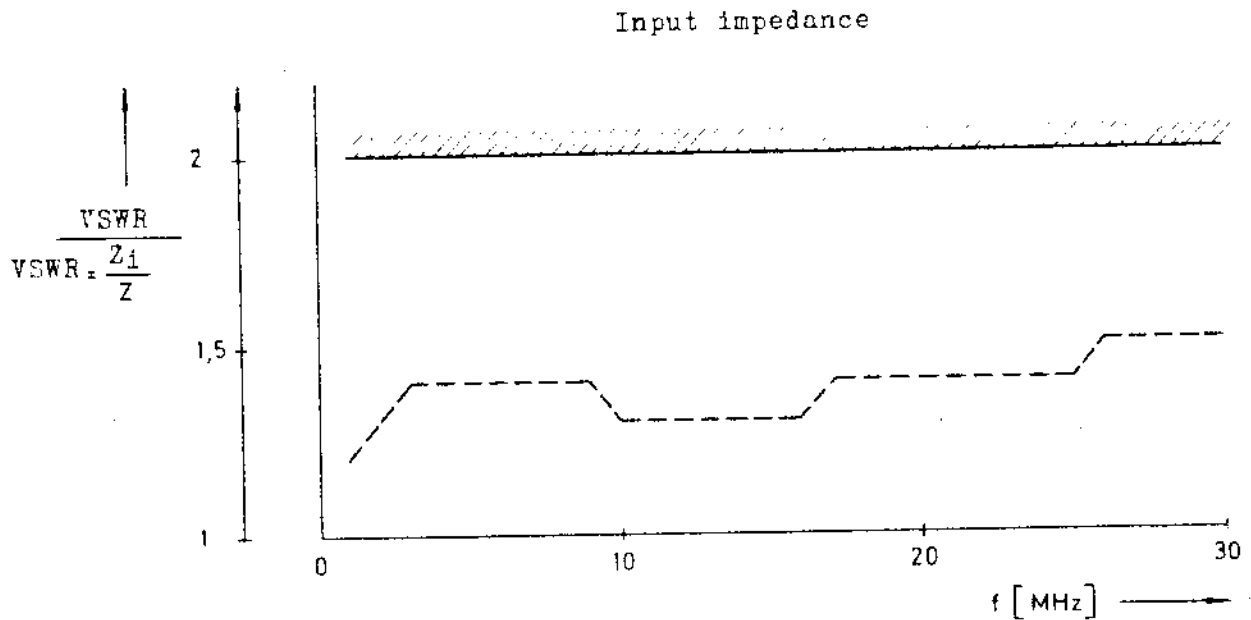

3.2.2.2. Isolation Between Outputs

Test Setup:

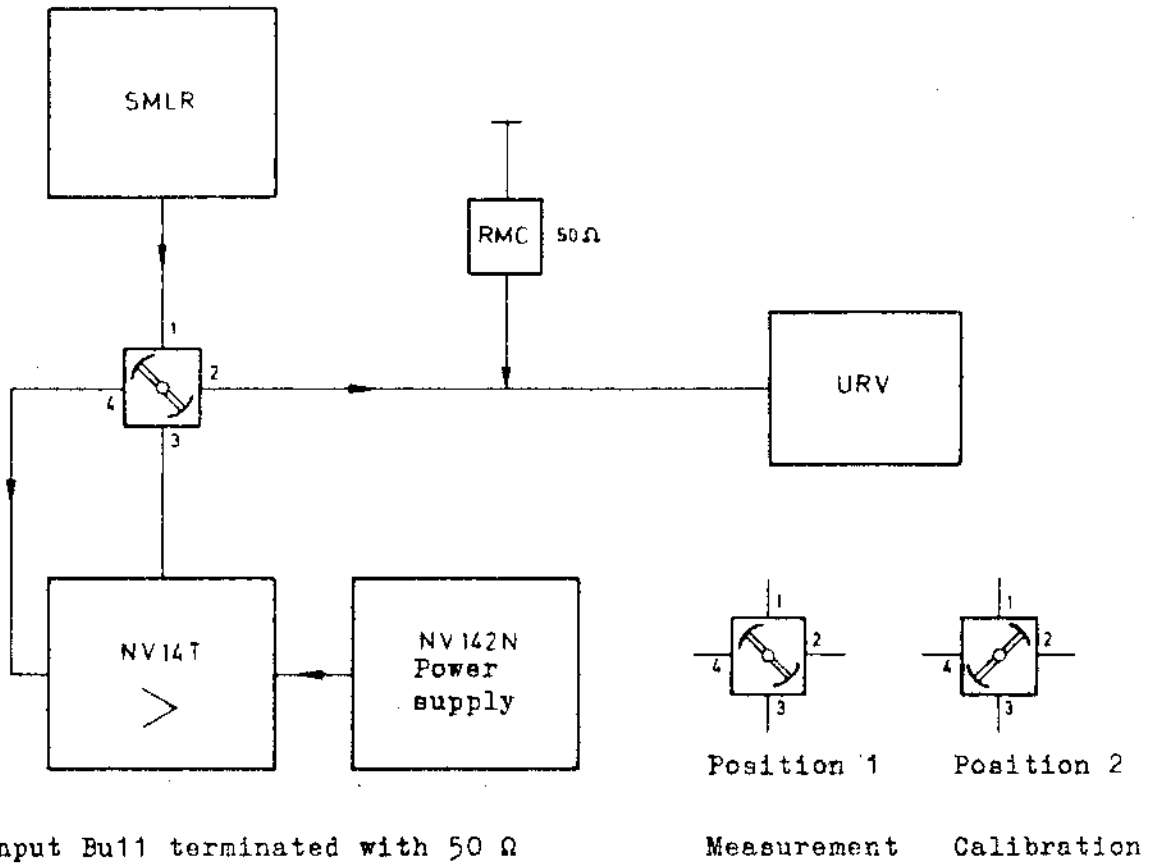

Measurement procedure:

Set the coaxial switch to position 1.

Adjust the SMLR to 0 dB in the 3-V range of the URV.

Set the coaxial switch to position 2.

Increase the sensitivity of the URV and read off the attenuation (decoupling).

Typical decoupling curve with tolerance limits:

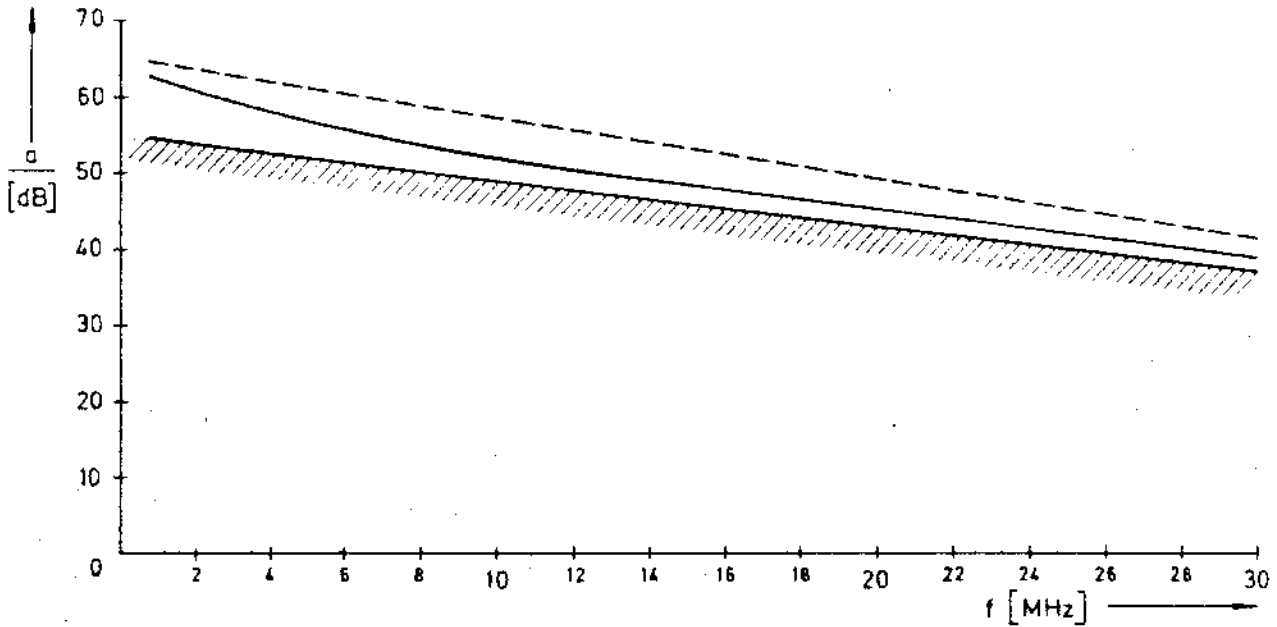

3.2.2.3. Noise Figure

First determine the noise figure of the Shortwave Receiver EK 07 using the SKTU.

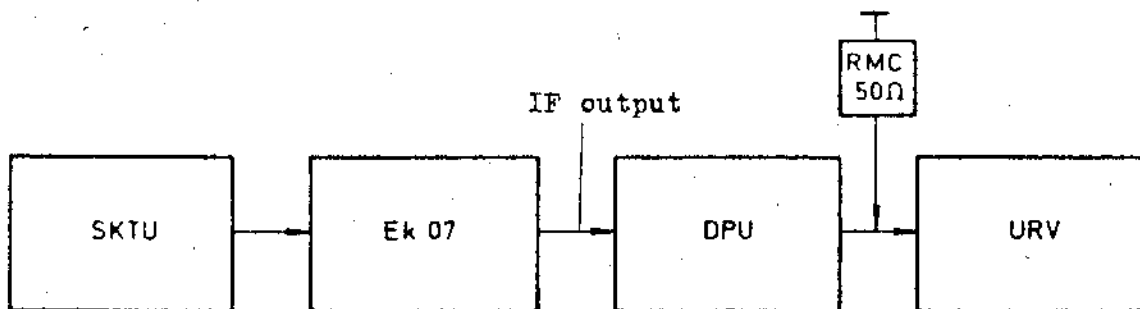

Measurement procedure:

Adjust the receiver to the test frequency required for measuring the noise figure and, using ± 6 kHz IF bandwidth, switch to MGC without the BFO. The output-voltage control of the Noise Generator SKTU is at 0. Advance the RF control of the receiver until the Millivoltmeter URV indicates about 50 mV with the UHF Attenuator Set DPU adjusted to 0 dB.

Do not vary the RF control of the receiver any more

Adjust the Attenuator Set DPU for an attenuation of 3 dB. The deflection on the URV sinks by this amount. Advance the output-voltage control on the SKTU until the URV indicates about 50 mV again. Read the noise figure of the receiver on the SKTU.

Then connect the Multicoupler NV 14 T between the noise generator and receiver and repeat the noise measurement without varying the RF control of the receiver.

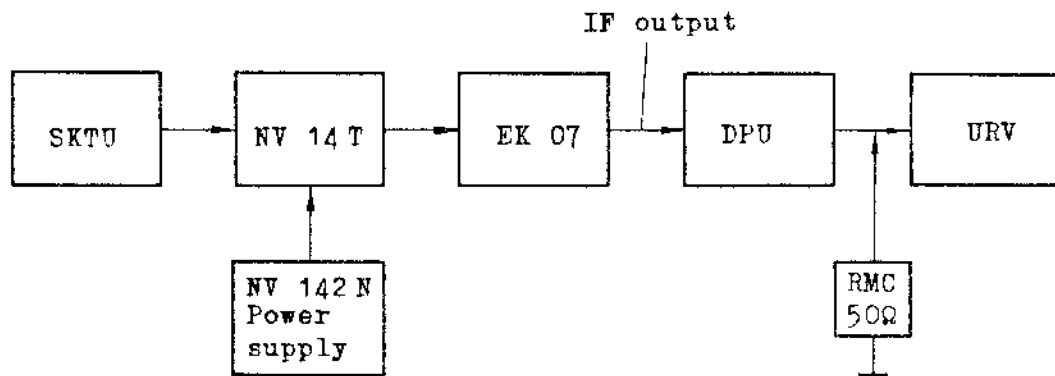

The value now measured is the total noise figure of the combination of NV 14 T and EK 07.

The noise figure of the Multicoupler NV 14 T can be calculated from the following equation:

$$N_{NV\ 14\ T} = N_{total} - \frac{N_{EK07} - 1}{A^2}$$

where

$N_{NV\ 14\ T}$ - noise figure of the Multicoupler NV 14 T in dB

N_{total} = total noise figure of the assembly in dB
 $N_{\text{EK 07}}$ = noise figure of the Shortwave receiver EK 07 in dB
 A = BMF gain of the Multicoupler at the test frequency
 (see 3.2.2.4).

(the gain is given as a factor and not in dB)

To obtain the noise characteristic as a function of frequency, repeat the measurement at different test frequencies. Vary the test frequency in steps of 5 MHz within the pass band of the Multicoupler, in steps of 1 MHz at the upper band limit and in steps of 100 kHz at the lower band limit.

During the measurement, check by means of a loudspeaker or phones at the receiver that the noise-figure measurement is not carried out at the frequency of a strong transmitter, since this would affect the result.

Tolerance limits:

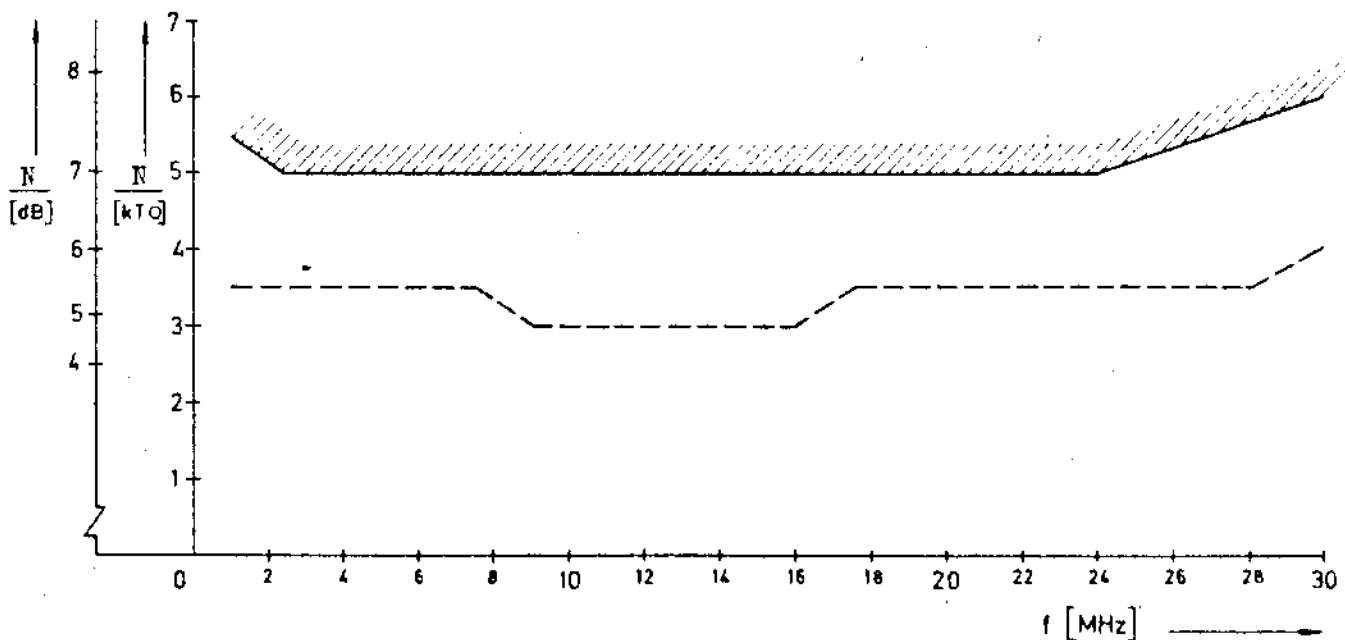

3.2.2.4. Gain

Test setup

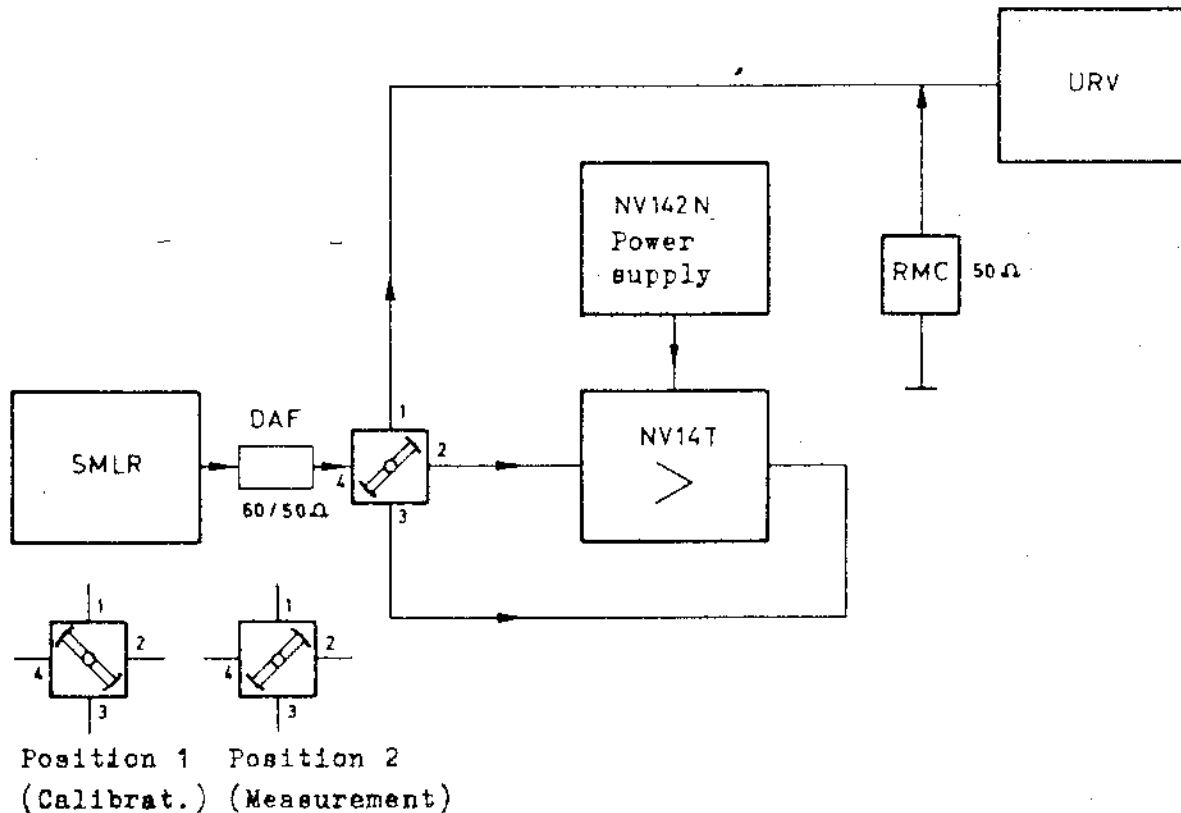

Measurement procedure:

Tune the SMLR to the required frequency and adjust the output voltage to 300 mV.

Bring the coaxial switch to position 1.

Vary the output voltage of the SMLR until the URV indicates 0 dB in the 300 mV range and bring the coaxial switch to position 2.

The departure from 0 dB indicated on the URV corresponds to the voltage gain in dB.

Rated value: $0 \pm 0,5$ dB between 1 and 30 MHz.

3.2.2.5. Suppression of Intermodulation Distortion ($d_2 + d_3$)

Test setup:

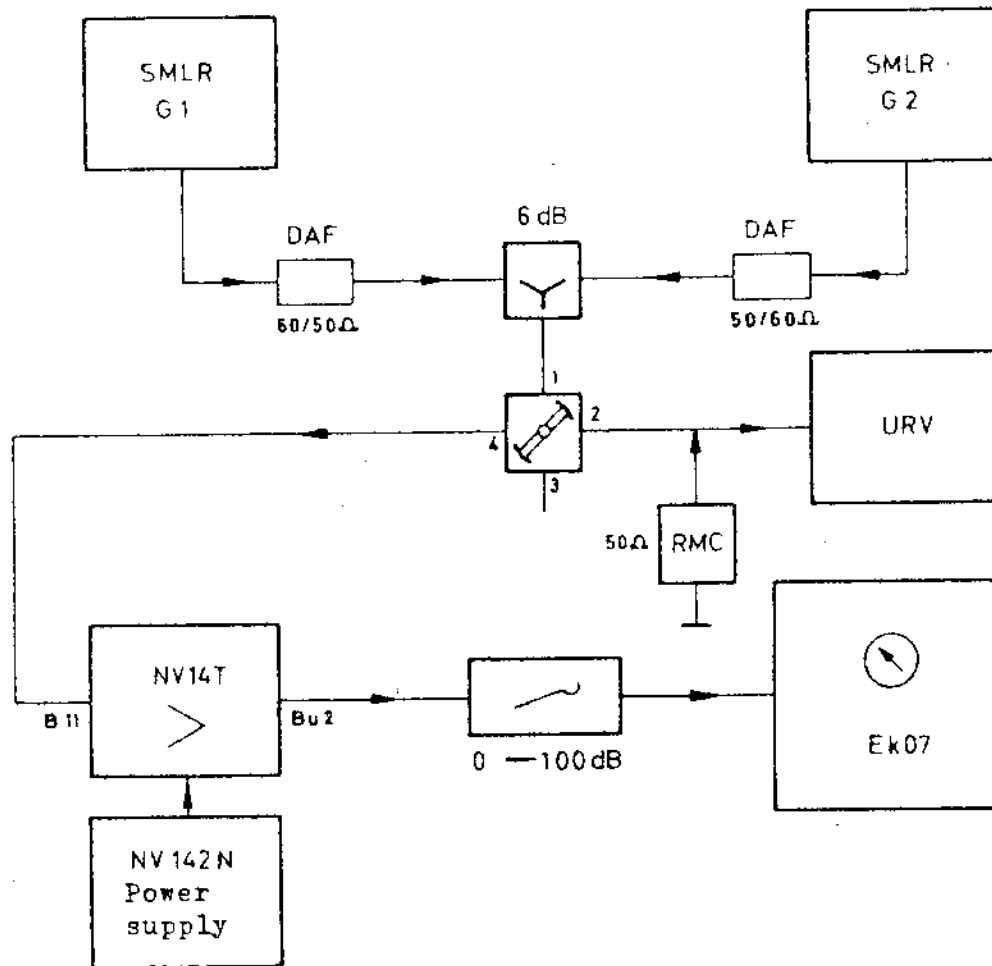

All outputs must be terminated with 50 Ω .

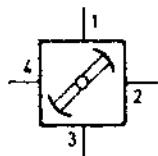

Position 1

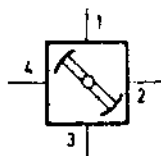

Position 2

Position 1 (1 - 2/3 - 4): Calibration

Position 2 (1 - 4/2 - 3): Measurement

Measurement procedure:

The measurement is started without the Multicoupler. The suppression of unwanted mixture products must be approx. 20 dB higher than with the Multicoupler.

The test frequency f_d for the 2nd-order mixture products is calculated:

$$f_{d2} = f_1 \pm f_2$$

and that for 3rd-order mixture products:

$$f_{d3} = f_1 \pm 2f_2 \text{ and } f_{d3} = 2f_1 \pm f_2.$$

Calibrating the receiver:

Adjust the DPU to 100 dB and set the output-voltage switch of G_1 to 0 dB/1 V, not modulated.

Set the range selector of the URV to 300 mV and the coaxial switch to position 1.

Tune G_1 to the test frequency and increase the output voltage until the URV indicates 150 mV_{rms} (the output voltage of G_2 must be 0 V).

Change the coaxial switch to position 2 and tune the EK 07 to f_d (zero beat).

With the EK 07 set for MGC, vary the RF control until the meter of the EK 07 shows some deflection, to the 10th scale division, for instance.

Adjusting the wanted frequencies f_1 and f_2 :

Tune G_1 to f_1 and switch the coaxial switch to position 1.

Increase the output voltage of G_1 until the URV indicates 150 mV_{rms} (the output voltage of G_2 must be 0 V).

Turn the output-voltage switch of G_1 to -40 dB/10 mV.

Turn the output-voltage switch of G_2 to 0 dB/1 V and tune to f_2 . Increase the output voltage until the URV indicates 150 mV_{rms}.

Set the coaxial switch to position 2 and output-voltage switch of G_1 to 0 dB/1 V.

Reduce the attenuation of the DPU by 70 to 80 dB.

Slight detuning of G_1 will cause a meter deflection on the EK 07.

Switch the DPU back in 1-dB steps until the former meter deflection is re-established (i.e. 10th scale division in our example).

100 dB minus the dB-setting of the DPU corresponds to the suppression of 2nd- and 3rd-order mixture products in dB.

Tolerance limits for the suppression of 2nd-order mixture products (d_2):

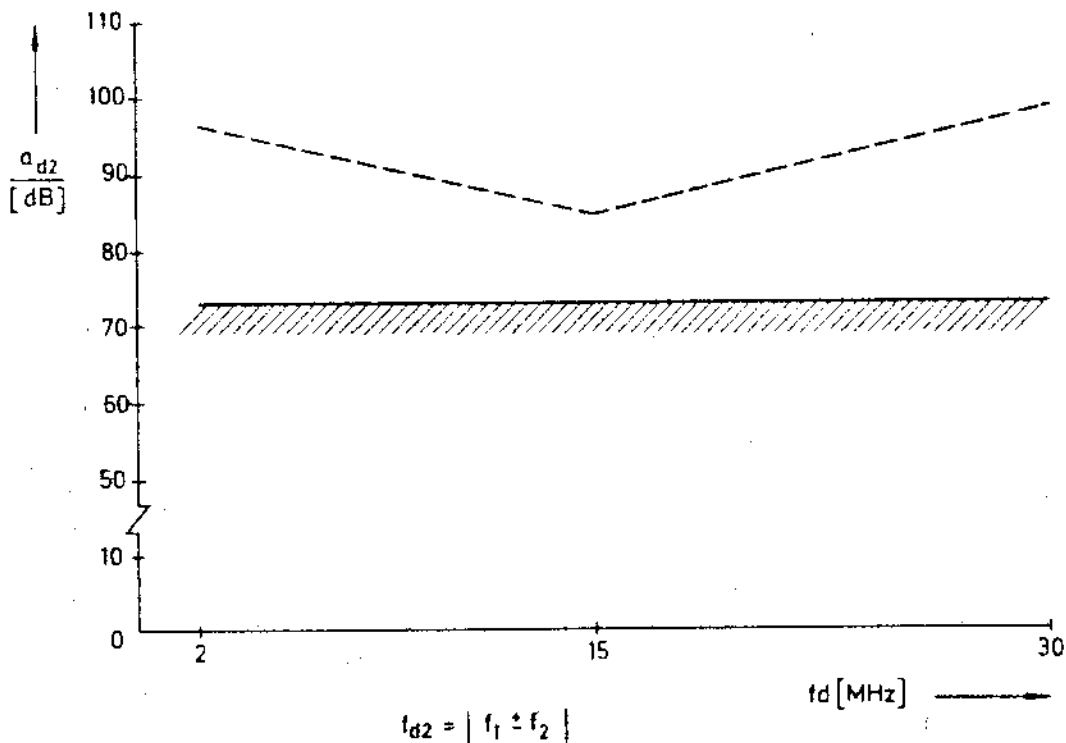

The suppression of unwanted mixture products in dB corresponds to the ratio between the emf ($Z = 50 \Omega$) of 2nd-order mixture products ($f_{d2} = f_1 \pm f_2$) and one of the two wanted signals (emf of f_1 and $f_2 = 300 \text{ mV}$, $Z = 50 \Omega$).

3.2.2.6. Cross Modulation

Test setup:

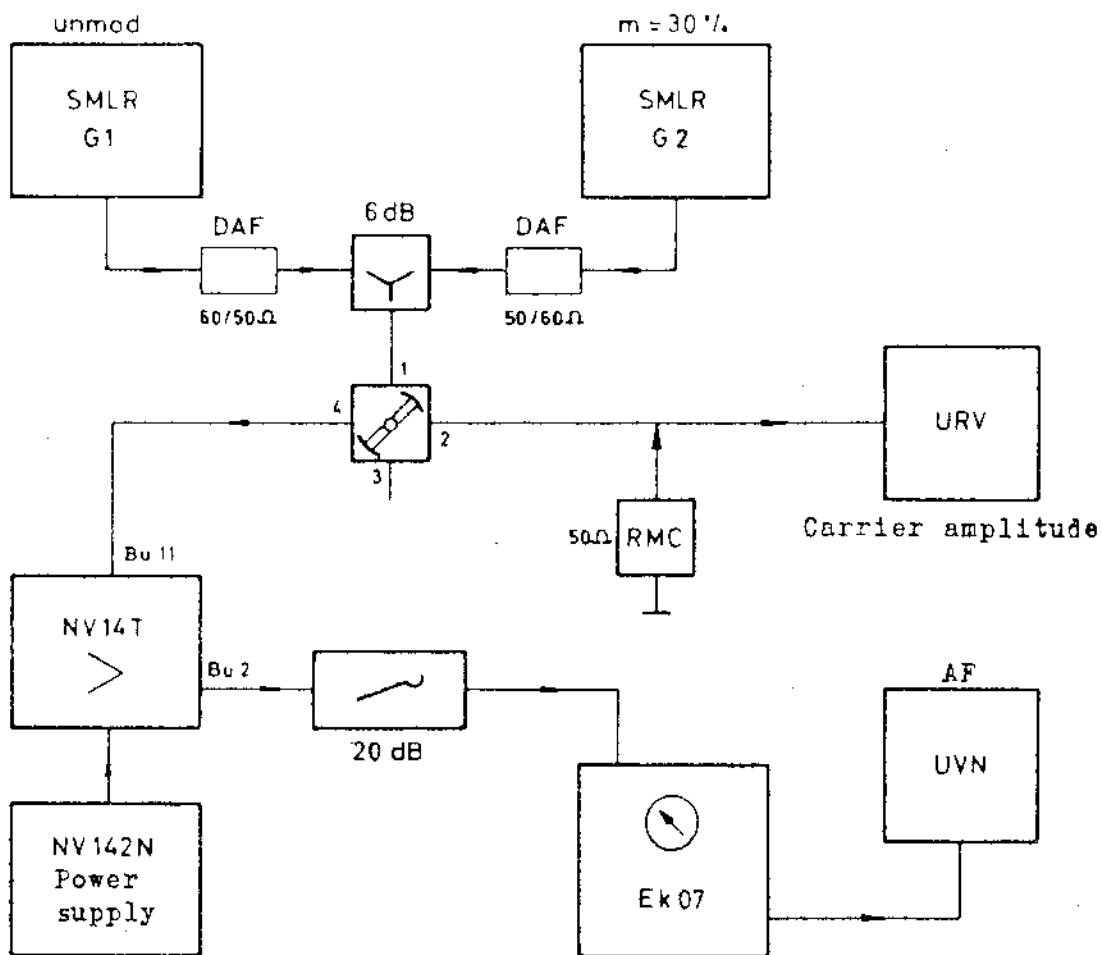

All outputs must be terminated with 50 Ω.

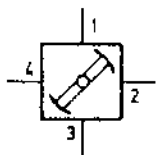

Position 1

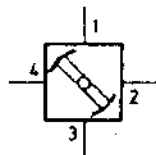

Position 2

Position 1 (1 - 2/3 - 4): Measurement

Position 2 (1 - 4/2 - 3): Adjustments

As in section 3.2.2.5, first measure the cross modulation of the test setup without the Multicoupler. With an emf of more than 12 V of the signal generator G1, the cross modulation should be 10%.

Adjust G2 to any frequency (f_N) within the passband of the Multicoupler (the output-level switch must be in position -40 dB/10 mV).

Tune the EK 07 (in the AGC mode) to f_N and increase the output voltage of G2 until the meter of the EK 07 indicates 100 μ V. Switch on the modulation (1000 Hz) with G2.

Measure the AF voltage with the UVN at the phones output. The AF voltage should be about 40 dB higher than the inherent noise of the test assembly which can be measured without modulation and with an output voltage of between 100 and 300 μ V of signal generator G1.

Increase the voltage with the AF control on the EK 07 until the UVN indicates 0 dB in the 300 mV range.

Switch off the modulation and change the frequency range of G2.

Tune G1 to f_N (range -40 dB/10 mV) and adjust the output voltage until the EK 07 indicates 100 μ V.

Switch G2 to 10/30 V, tune to the interfering frequency and switch on the modulation.

Increase the sensitivity of the UVN by 20 dB (switchover to range 30 mV) and increase the output voltage of G2 until the UVN indicates 0 dB (corresponding to 10% cross modulation on the wanted frequency).

Set the coaxial switch to position 1 and read off the voltage on the URV (the emf for 10% cross modulation is obtained by doubling the indicated value).

Typical cross-modulation characteristics:

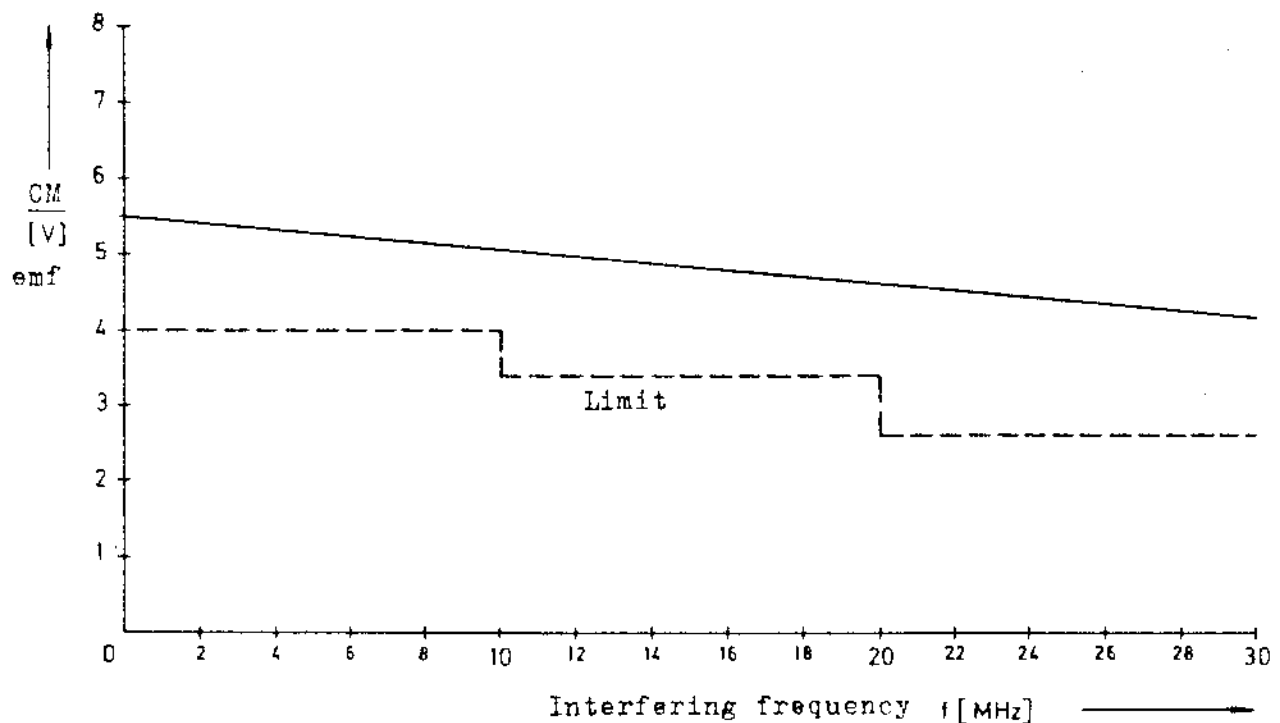

3.2.3 Recalibration

In the case of failure, proceed according to the Repair Instructions (see section 3.3).

3.2.4 Mechanical Maintenance

Clean the front panel only with a dry, lint-free cloth. If it is very dirty, alcohol may be used but on no account abrasives, such as Ajax, or varnish removers.

The unit is almost dust-sealed, so that the interior need only be cleaned during repair work by blowing through a weak stream of compressed air. Care must be taken during this process not to damage any frequency-determining parts or lines.

3.3 Repair Instructions

3.3.1 Circuit Description

(see block diagram Fig. 4 and circuit diagram NV 14 T S)

3.3.1.1 Overvoltage Protection and Filter

The arrester Si1 connected to chassis between the input and the filter protects the Multicoupler from destruction by lightning voltages. The spark gap can eliminate pulse currents up to 5 kA at a breakdown voltage of about 90 V and an arc drop of about 20 V as often as required. The direct connection of the input to chassis via L1 prevents the arrester from responding periodically due to static charges of the antenna.

The two-section filter determines the bandwidth of the Multicoupler and prevents unwanted mixture products of strong interfering transmitters outside the useful frequency range from appearing in the reception range.

The filter consists of a low-pass section, C1, C3, L3, L4, and a high-pass section, C5 to C9, L6, L7.

The diodes G1 14, G1 15 are reverse-biased and limit the residual overvoltage that is not suppressed in the filter to about 12 V_{pp}. The transformer Tr1 matches the output of the filter to the amplifier section of the Multicoupler.

3.3.1.2 Amplifier Section

The preliminary stage of the Multicoupler consists of two complementary transistors, T5 and T6, which operate in a push-pull, common-base arrangement. The operating point, which is thermally stabilized by diodes G1 16, G1 17, G1 18, can be adjusted with R39, and the balance of the stage with R42. The operating resistors R45 and R46 are bypassed by L11 and L12, so that transistors T5 and T6 are fed with the full supply voltage.

The next two stages of the amplifier section, the driver and output stages, are DC-coupled and operate in a push-pull, common-collector circuit. The complementary transistor pair T7, T8 forms the driver stage and T9, T10 the output stage.

3.3.1.3 Output Coupling Network

The output impedance of the output stage is less than 1 Ω in the entire frequency range.

If a spurious signal arrives at an output of the Multicoupler, the series resistance of the output and the low output impedance of the output stage cause a voltage division of 34 dB, and the series resistances of the other outputs and the externally connected load impedances cause a voltage division of 6 dB.

In this way, all outputs of the Multicoupler are mutually isolated by at least 40 dB.

3.3.1.4 Negative Feedback

The output of the amplifier section is fed back to the base of the preliminary stage via transformer Tr2. The gain of the common-base circuit is utilized down to about 1 dB for the feedback, which covers all three stages. This ensures a high overdrive capability. The feedback factor is selected such that the noise and power matching in the input stage coincide.

3.3.1.5 Current Regulator

A current regulator has been provided to minimize the effect of temperature on the output current of the final stage.

This current flows through resistor R4 in the base-emitter line of one half of the double transistor T1, which operates as a differential amplifier. The rated value is adjusted with R11.

Current variations in the output stage cause corresponding voltage variations across R4, which, in turn, affect the collector current.

Since this flows also through the common emitter resistor R6 and the current through this resistor is always constant, it must be the collector current of the second transistor half that varies. This current affects directly the base circuit of T7 and drives this transistor more or less into conduction, depending on the rated value of the output current adjusted for.

3.3.1.6 Voltage Regulator

Another regulator is provided to stabilize the voltage at the junction of the emitters of the complementary transistors T9 and T10, and which is applied to one input of the double transistor T2, which operates as a differential amplifier. The voltage divider R17, by means of which the rated voltage can be adjusted, is connected ahead of the second input.

As soon as this emitter voltage changes, the differential amplifier responds with a corresponding change of the collector current. This acts on the output transistor T10 via the driver T8 and varies its collector-emitter voltage, and consequently also the voltage present at the junction of the emitters of T9 and T10 until the adjusted nominal value is obtained.

3.3.2 Mechanical Construction

After removal of the side panels of the unit, the circuitry is accessible from both sides. The subassemblies are accommodated in individual compartments (see Figs. 2 and 3). Compartment 1 contains a printed-circuit board with the input filter. Compartment 2 contains another printed circuit with the preliminary stage; the transistors T5 and T6 of this stage can be taken out of their heat sinks after unscrewing four cheese-head screws and unsoldering the electrical connections on the wiring side of the board. Compartment 3 houses the conventionally wired driver and output stage, whereas compartment 4 accommodates the circuits for current and voltage regulation. When replacing transistors ensure that all leads are connected exactly as before. Since the emitter of T10 must not be taken to chassis although it is internally connected to the transistor case, care must be taken when mounting T10 that it is insulated from the multicoupler chassis. Compartment 5 contains an overvoltage arrester. The 11 RF connections (1 input, 10 outputs) and a socket for the connection of the power supply are located on the rear wall (see Fig. 1).

3.3.3 Repair

If checks of the Multicoupler reveal that the specifications are no longer complied with, proceed as described below to cure the fault.

3.3.3.1 Input Impedance

If the nominal VSWR of < 2 is exceeded, correct the input impedance with L6/L7 at the lower and with L3/L4 at the upper limit frequency.

L3, L4, L6 and L7 are provided on the filter board NV 14 T-21 (1.6 to 30 MHz) or NV 14 T-22 (1 to 30 MHz).

3.3.3.2 Gain

If the gain departs from the nominal value, 0 ± 0.5 dB, it can be corrected with L7 at 1 (1.6) MHz and with L4 at 30 MHz. L4 and L7 are provided on the boards NV 14 T-21 and NV 14 T-22 (see also section 3.3.3.1).

After any adjustments have been made as described in sections 3.3.3.1 and 3.3.3.2, it is necessary to check the pass-band characteristics since an adjustment of L7 affects the pole frequency. (Also check that the attenuation values are maintained).

3.3.3.3 Noise Figure

When sensitivity measurements reveal any departures from the rated value, make sure that these are not caused by one of the following reasons:

- a) The measurement was carried out on an unwanted carrier (check with headphones).
- b) The individual measurements of N_{total} , N_{rec} , and A were not made with sufficient accuracy.
- c) Connecting cables ahead of the input are interrupted or make poor contact.

3.3.3.4 Unwanted Mixture Products d_2 and d_3

Check the test setup before measuring the unwanted 2nd- and 3rd-order mixture products.

The suppression of d_2 and d_3 of the test setup without Multicoupler should be approx. 20 dB higher than with Multicoupler. If this is the case and the suppression of d_2 , but not of d_3 , is insufficient, the balance of the various amplifier stages must be readjusted. To do so, the Digital Multimeter UGWD is first connected to the emitters

of T5 and T6 (driver), and the voltage is adjusted to 11.8 ± 0.2 V with R42.

The output stage is balanced by connecting the UGWD to the emitters of T9 and T10 and adjusting the voltage to 11.7 ± 0.2 V with R17.

After these adjustments, the mixture products must be measured once again and the amplitude of d_2 adjusted to minimum with R42 and R17.

If the suppression of the 3rd-order mixture products, d_3 , or the cross modulation do not agree with the rated specifications, the current of the driver and output stage must be adjusted. For this purpose, the link between points 15 and 16 on the driver board must be removed and the ammeter URI connected in between (positive pole at point 15). The current is adjusted to the rated value of 50 ± 3 mA with R39. The ammeter is then inserted in the current-supply line of the output stage, and the current adjusted to 200 ± 5 mA with R11.

Rear view: connection panel

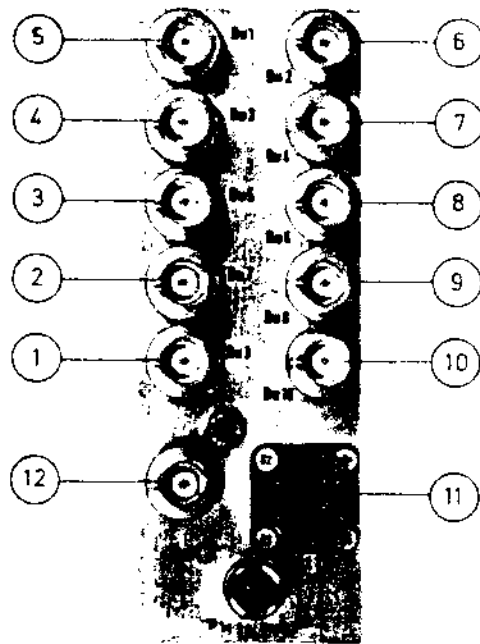

[Key in section 2]

Internal view: component side

Compartment 4

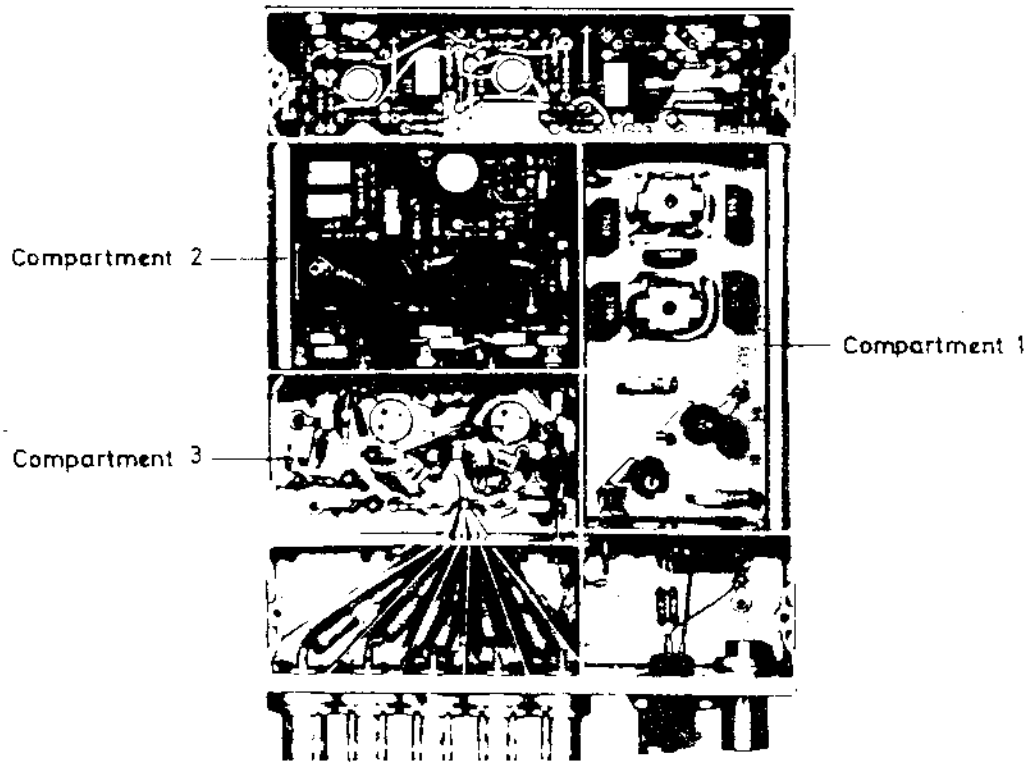

(Key in section 3.3.2)

Internal view: conductor side

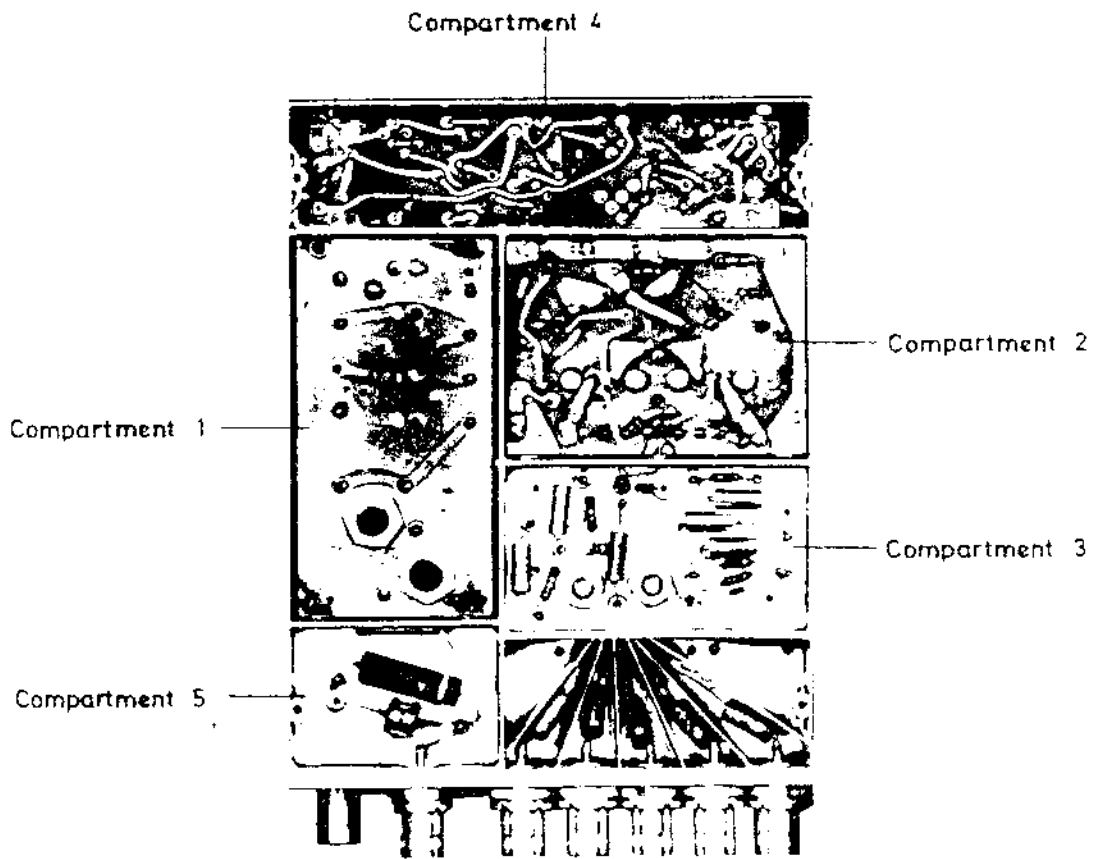

(Key in section 3.3.2)

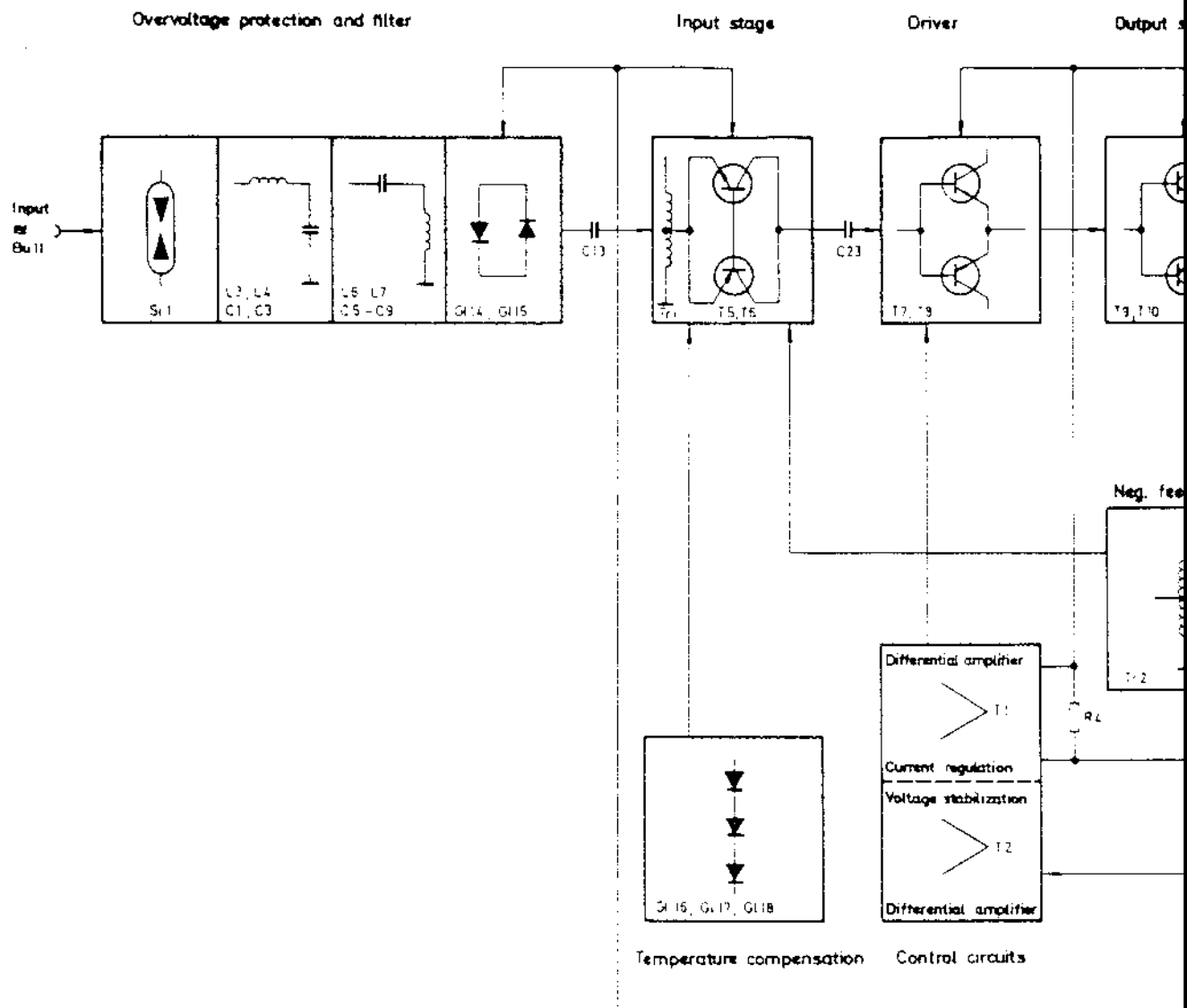

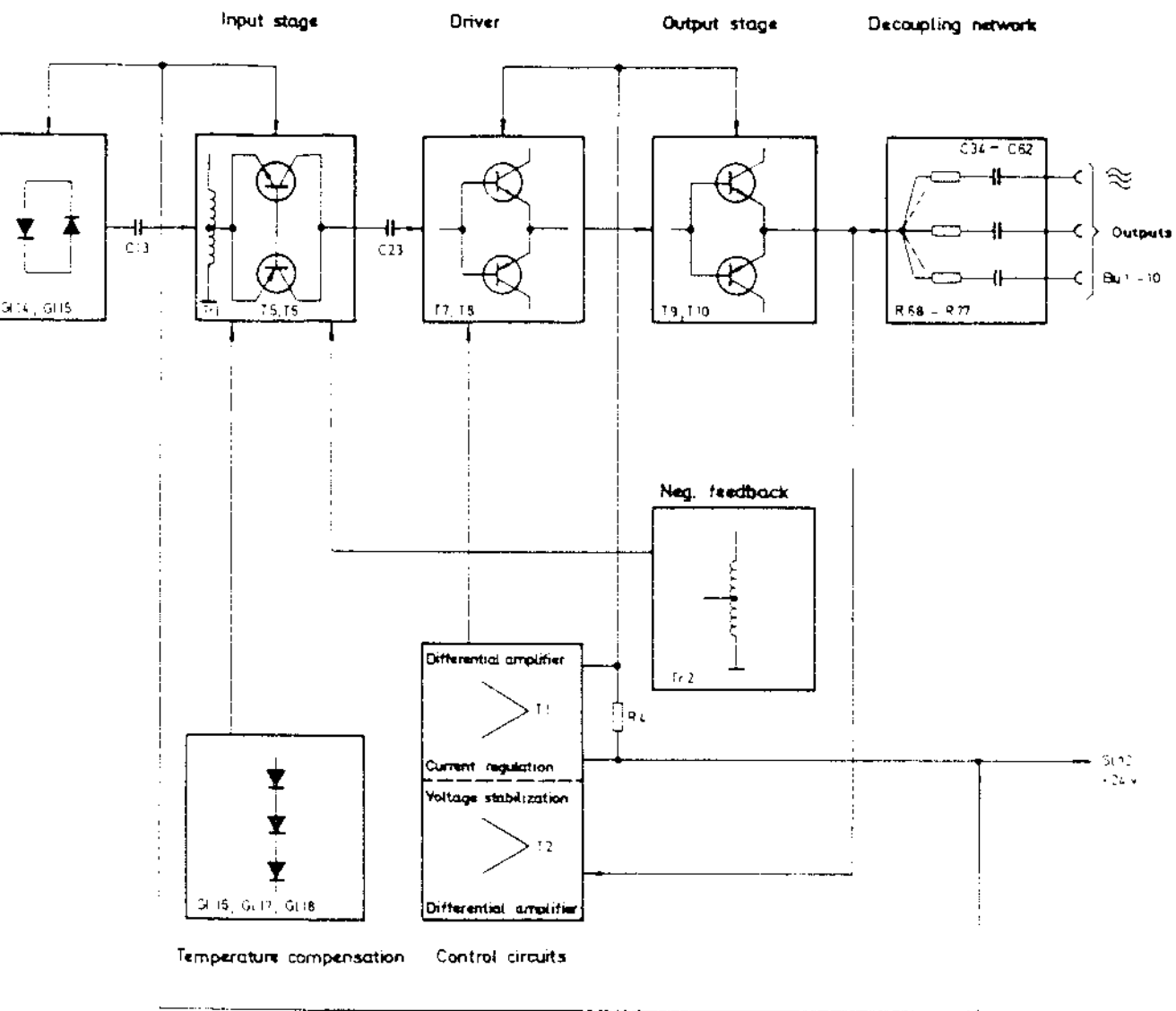

Block diagram of NV14 T

Fig. 4

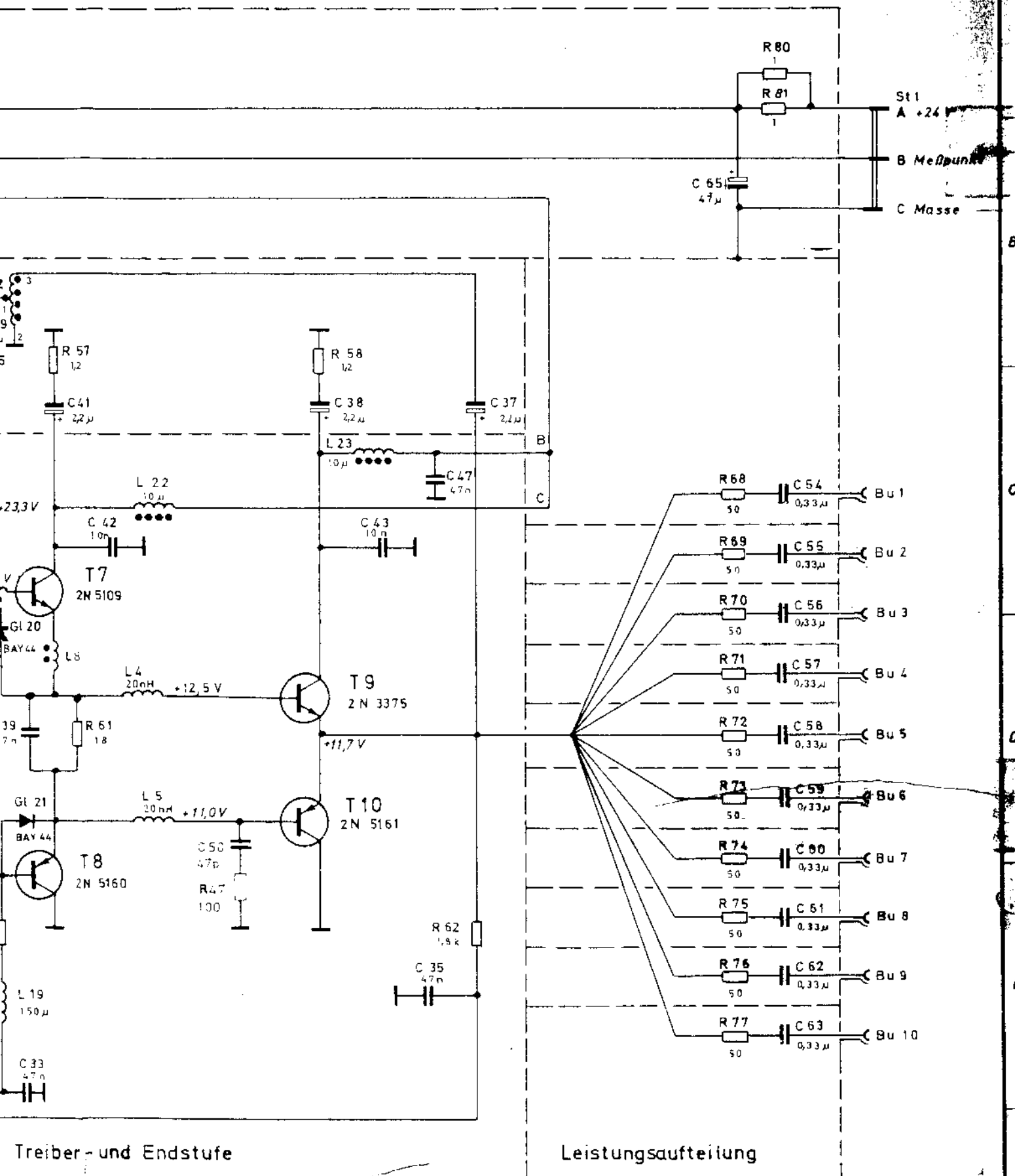

Stromlauf gilt für NV14T u. NV14T-100

hierzu NV14T Sa

<p>Stromlauf zu</p> 	<p>HF-Trennverstärker</p>	<p>Zeichn. Nr. NV 14 T S</p>
---	---------------------------	----------------------------------

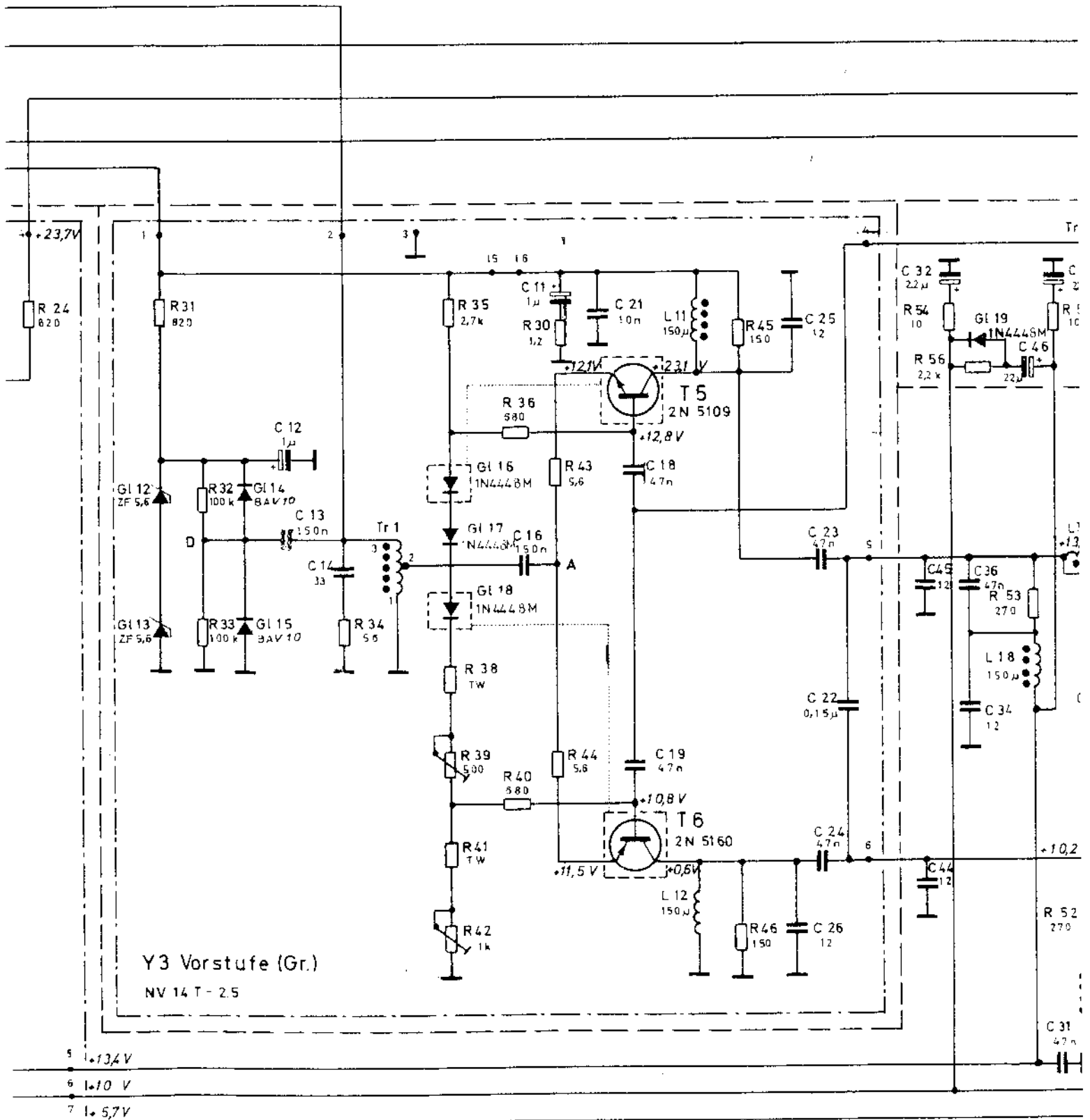

T6, T7, T8



Gleichspannungswerte gemessen mit Instrument $R_i \approx 10M\Omega$

zu Y2: NV 14 T - 15 Sa

zu Y3: NV 14 T - 2.5 Sa

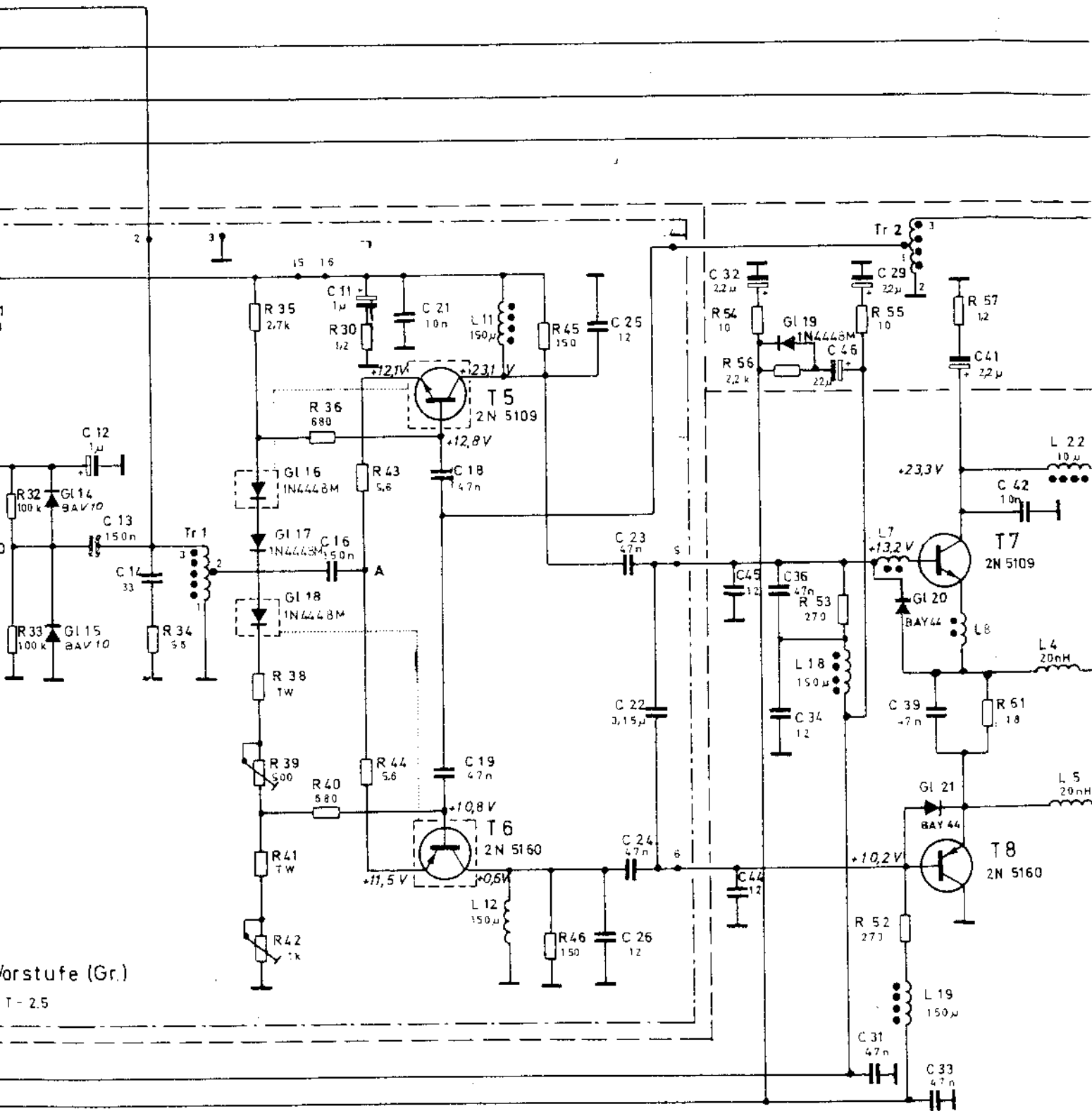

vorstufe (Gr.)
T-2.5

Treiber- und End

Stromlauf

Gleichspannungswerte gemessen mit Instrument $R_i \approx 10M\Omega$

zu Y2 : NV 14 T-15 Sa

zu Y3 : NV 14 T-2.5 Sa

